

R16

Code No: 132AE

JAWAHARLAL NEHRU TECHNOLOGICAL UNIVERSITY HYDERABAD

B.Tech I Year II Semester Examinations, January/February - 2024

ENGINEERING GRAPHICS

(Common to EEE, ECE, CSE, EIE, IT)

Time: 3 Hours

Max Marks: 75

**Answer any five questions
All questions carry equal marks**

- 1.a) Construct a diagonal scale showing yards, feet and inches in which 2 inches long line represents 1.25 yards and is long enough to measure up to 5 yards. Find R.F. and mark a distance of 4 yards 2 feet 8 inches.
- b) The major axis of an ellipse is 110 mm long and the foci are at a distance of 15 mm from the ends. Draw the ellipse, one-half of it by concentric circles method and the other half by rectangle method. Find the directrix and eccentricity of the ellipse. [7+8]

OR

- 2.a) Construct a diagonal scale showing hectometers, decameters and metres, in which 1 cm long line represents 50 metres and long enough to measure up to 1 km. Find R.F. and mark a distance 5 Hm 3Dm 7m on it.
- b) A circle of diameter 50 mm rolls for a distance of 180 mm along a straight line. Draw the locus of a point lying on the circumference of the circle. Name the curve traced. [7+8]

- 3.a) A straight line AB has its end A 20 mm above the H.P. and 30 mm in front of the V.P. and the end B is 80 mm above the H.P. and 70 mm in front of the V.P. If the end projectors are 60 mm apart, draw the projections of the line. Determine its true length and true inclinations with the reference planes.
- b) A 70 mm long line AB has its end A 20 mm above the H.P. and 30 mm in front of the V.P. The line is inclined at 45° to the H.P. and 30° to the V.P. Draw its projections. [7+8]

OR

4. A hexagonal plane of side 30 mm has a corner on the ground. Its surface is inclined at 45° to the H.P. and the top view of the diagonal through the corner which is in the H.P. makes an angle of 60° with the V.P. Draw its projections. [15]

5. A cylinder of base diameter 50 mm and axis 70 mm has a point of its base circle in the V.P. Its axis is inclined at 30° to the V.P. and 45° to the H.P. Draw its projections. [15]

OR

- 6.a) A pentagonal prism of base edge 30 mm and axis 60 mm rests on an edge of its base in the H.P. Its axis is parallel to V.P. and inclined at 45° to the H.P. Draw its projections.
- b) A pentagonal pyramid of base side 30 mm and axis 60 mm has an edge of base parallel to H.P. Its axis is parallel to V.P. and inclined at 45° to the H.P. Draw its projections when the apex lies in the H.P. [7+8]

QA QA QA QA QA QA QA QA QA

7. A cone of base diameter 50 mm and axis 60 mm rests on its base in the H.P. It is cut by a section plane perpendicular to V.P. such that the true shape of the section is a parabola of base 40 mm. Draw its three views and obtain the true shape of the section. [15]

QA QA QA QA QA QA QA QA QA

OR

8. A cylindrical drum of base diameter 50 mm and axis 70 mm is resting on its base on the H.P. A square hole of side 40 mm is cut through the drum such that one of the faces of the square hole is inclined at 30° to the H.P. The axis of the hole is perpendicular to the V.P. and is 10 mm away from the axis of the cylinder. Draw the development of the retained cylinder. [15]

QA QA QA QA QA QA QA QA QA

9. Draw the following views of the drawing shown in figure 1 below. (a) Front view in the direction of arrow (b) Side view from the right (c) Top view. (All dimensions are in mm) [15]

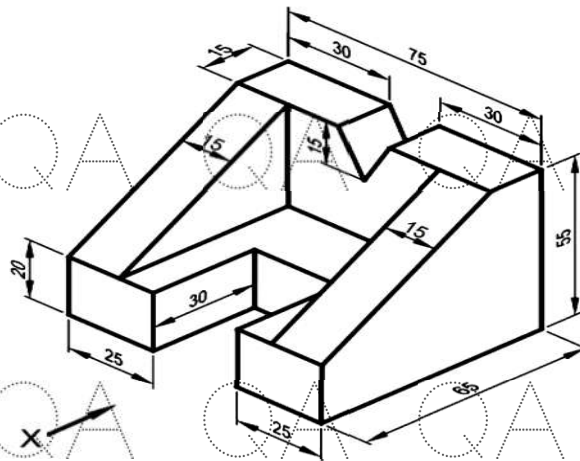

Figure 1

OR

10. Draw the isometric view from the figure 2 showing orthographic views of an object shown below. (All dimensions are in mm) [15]

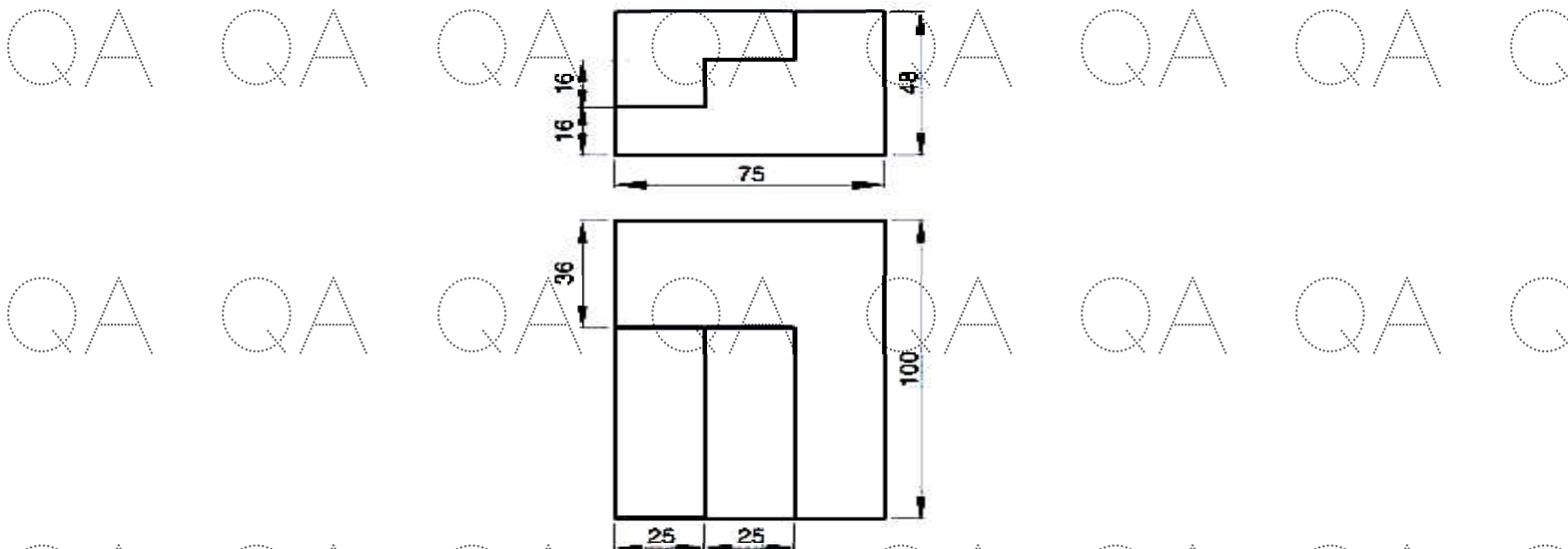

Figure 2